

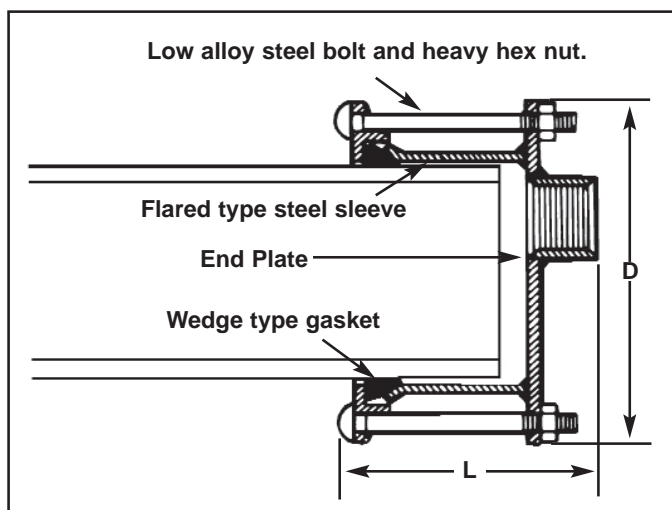

Smith-Blair Steel Pipe End Caps are easy to remove, re-install and block. They are an ideal means of capping the line for testing, and they also make a dependable pipe end seal for permanent installation. An offset outlet is conveniently located to allow for blow-off or draining the line.



Material Specifications

- SLEEVE:** ASTM A-53, ASTM A-513 or carbon steel having a minimum yield of 30,000 psi.
- END PLATE:** Mild steel with a 2" I.P. threaded outlet. Other outlet sizes available upon request.
- FOLLOWERS:** Ductile Iron ASTM A536 or AISI C1020 steel
- GASKETS:** Nitrile (Buna-N)-NSF®61-Compounded to produce superior storage and performance characteristics while resisting water, acids, alkalies, most (aliphatic) hydrocarbons and many other chemicals. Temperature range -20°F to 180°F. Consult manufacturer for specific applications or other service temperatures.
- BOLTS & NUTS:** High-Strength, low alloy steel with heavy, semi-finished hexagon nuts.
- FINISH:** Fusion bonded Flexi-Coat Epoxy.

Material Specifications are subject to change.

Nom. Pipe Size In.	Pipe O.D. Inches	Catalog Number	Overall Diameter Inches (D)	Overall Length Inches (L)	Approx. Shipping Wt. Lbs.
2	2.50	481-02500114-003	6.20	7.94	10
3	3.74	481-03740114-003	7.30	7.94	11
	3.80	481-03800114-003	7.06	8.19	12 1/2
	3.88	481-03880114-003	7.06	8.19	12 1/2
	3.96	481-03960114-003	7.53	8.19	12 3/4
4	4.64	481-04640114-003	8.13	8.19	17 1/2
6	6.90	481-06900118-003	10.56	8.19	28
9	9.05	481-09050114-003	13.44	8.19	39
10	11.10	481-11100114-003	15.13	8.19	45 1/2
	11.40	481-11400114-003	15.13	8.19	53
	11.66	481-11660114-003	16.50	8.19	53 1/2
12	13.20	481-13200114-003	17.47	8.31	53 1/2
	13.50	481-13500114-003	17.47	8.31	58 3/4
	13.92	481-13920114-003	18.31	8.31	73
14	15.30	481-15300114-003	19.75	8.31	89
	15.65	481-15650114-003	20.10	8.31	92
16	17.40	481-17400114-003	21.84	8.31	92 1/4
	17.80	481-17800114-003	22.25	8.31	92 1/2
18	19.50	481-19500114-003	24.00	8.31	122
	19.92	481-19920114-003	24.40	8.31	125
20	21.60	481-21600114-003	26.30	8.31	136
	22.06	481-220060114-003	26.50	8.31	138

Other sizes available upon request.

Pipe end caps must be securely blocked or anchored to prevent them from moving off of the pipe.