

TYPE 632
TAPPINGSLEEVE
 for Gas Service

INSTALLATION INSTRUCTIONS

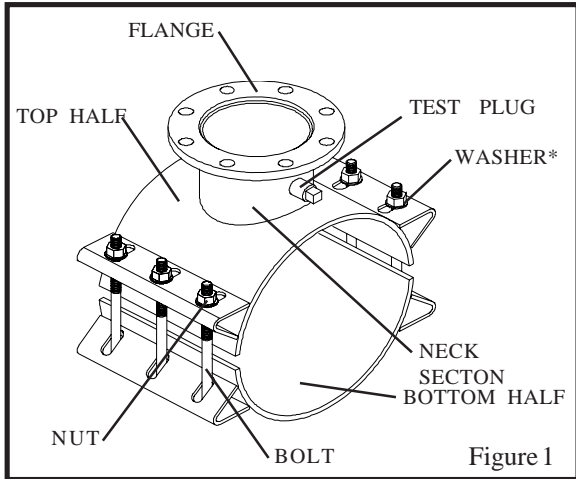
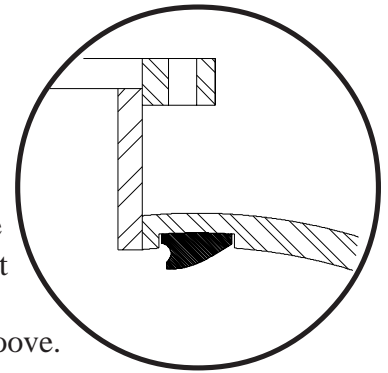

■ Visually inspect your Smith-Blair Tapping Sleeve prior to installation to ensure that no damage has occurred during shipment or storage.

Make certain gasket is secure in gasket groove. (See Gasket Detail Inset)

■ Check pipe outside diameter where sleeve will be installed to insure that the correct Tapping Sleeve is being installed.

Note: Pipe must be round in the area where sleeve will fit:

4" thru 24"	± .06"
30" thru 48"	± .12"
Above 48"	± .19"

■ Thoroughly clean pipe surface so that it is smooth and free of dirt, corrosion and/or other debris that may impair gasket seal.

■ Lubricate pipe and gasket with soap solution. Antifreeze should be added in freezing weather.

■ Disassemble nut & bolts and remove outlet half of Tapping Sleeve. (See Figure 2)

■ Mount outlet half on pipe with the flange oriented in the position required for permanent installation making sure test plug is accessible. (See figure 3)

NOTE: Extra precaution should be made at this stage of installation to insure that the flanged portion of the sleeve is mounted on the pipe in a direct "head-on" direction. This will insure that the gasket will not be damaged, pulled or rolled out of the groove in the sleeve. Damage will occur if these instructions are not followed.

■ Install bolts, nuts and washers. Hand tighten nuts, keeping equal gaps between body halves. (See figure 3)

* Stainless bolts and nuts will be supplied with a plastic washer which is used between the nut and metal washer.

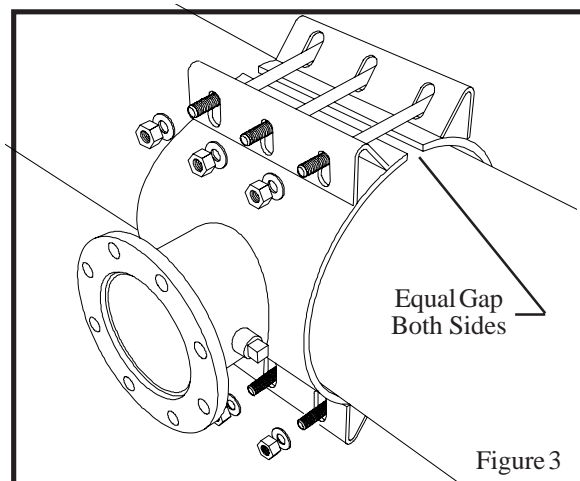
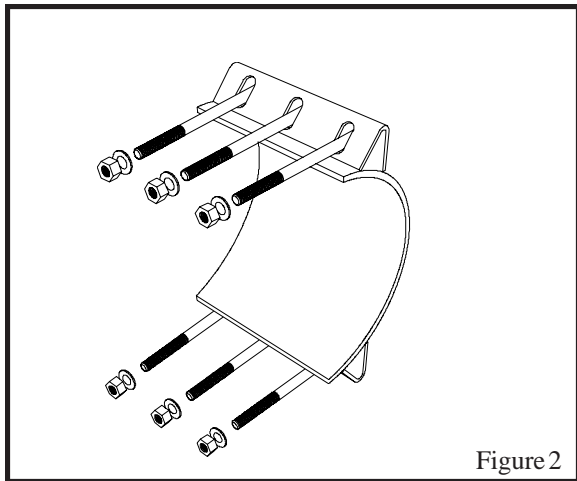

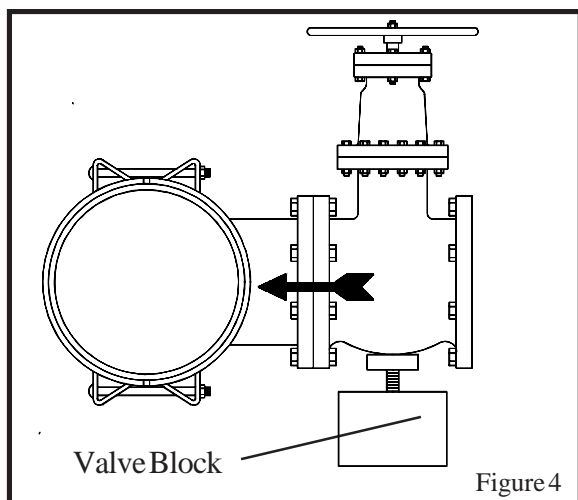

- Proper and sufficient blocking of the valve and/or tapping equipment will be necessary. Improper blocking will cause the sleeve to pull away from the pipe and proper torquing of the bolts will not be achieved. On some installations the valve and/or tapping machine may be installed on the sleeve prior to hoisting in trench. (See Figure 4)

- Tighten bolts starting from the outside inward, alternating from one side to the other, to equalize the gap between the halves. Continue to tighten bolts until sleeve halves conform to the contour of the pipe and all bolts are to a uniform tightness (See Figure 5). See Table 1 for recommended bolt torque values.

Table 1

Bolt Torque	
50-60 ft-lbs	5/8 Bolts
90-100 ft-lbs	3/4 Bolts
100-120 ft-lbs	1" Bolts

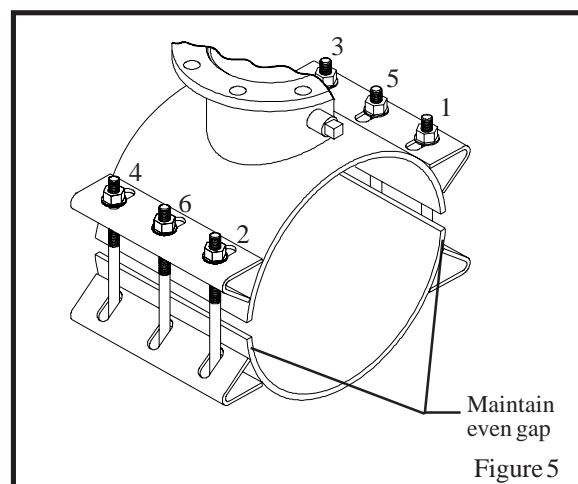

CAUTION

Failure to evenly tighten all nuts to the required torque may result in failure of the tapping sleeve. The tapping sleeve will not function properly if the nuts on only the top side of the tapping sleeve are tightened! Make sure the nuts on the bottom of the sleeve are tightened to the proper torque!

- A pressure test is recommended prior to tapping to test the seal. * **If using Pneumatic Test follow proper safety precautions.** For pipe diameters larger than 36": Pressurize to operating pressure; release pressure; re-torque again to proper torque; Pressure test at full test pressure. Pressure test should not exceed 1.5 times actual line pressure.
- Proceed with the tapping operation

INSURE PROPER CLEARANCE BETWEEN CUTTER & NECK/OUTLET INSIDE DIAMETER.

CAUTION

Be sure to permanently block and support the valve and pipe prior to the tapping operation. Failure to do so may cause damage to the pipe or sleeve.

- Check nuts for tightness and re-torque if required. If possible, nuts should be checked for tightness 12-24 hours after initial tightening.